

Write your name here

Surname

Other names

Pearson Edexcel Certificate
Pearson Edexcel
International GCSE

Centre Number

--	--	--	--	--

Candidate Number

--	--	--	--

Physics

Unit: KPH0/4PH0

Paper: 2P

Friday 17 June 2016 – Morning

Time: 1 hour

Paper Reference

KPH0/2P
4PH0/2P

You must have:

Ruler, calculator

Total Marks

Instructions

- Use **black** ink or ball-point pen.
- **Fill in the boxes** at the top of this page with your name, centre number and candidate number.
- Answer **all** questions.
- Answer the questions in the spaces provided
– *there may be more space than you need.*
- Show all the steps in any calculations and state the units.
- Some questions must be answered with a cross in a box ☒. If you change your mind about an answer, put a line through the box ~~☒~~ and then mark your new answer with a cross ☒.

Information

- The total mark for this paper is 60.
- The marks for **each** question are shown in brackets
– *use this as a guide as to how much time to spend on each question.*

Advice

- Read each question carefully before you start to answer it.
- Write your answers neatly and in good English.
- Try to answer every question.
- Check your answers if you have time at the end.

Turn over ►

P45692A

©2016 Pearson Education Ltd.

1/1/1/1/



PEARSON

EQUATIONS

You may find the following equations useful.

$$\text{energy transferred} = \text{current} \times \text{voltage} \times \text{time}$$

$$E = I \times V \times t$$

$$\text{pressure} \times \text{volume} = \text{constant}$$

$$p_1 \times V_1 = p_2 \times V_2$$

$$\text{frequency} = \frac{1}{\text{time period}}$$

$$f = \frac{1}{T}$$

$$\text{power} = \frac{\text{work done}}{\text{time taken}}$$

$$P = \frac{W}{t}$$

$$\text{power} = \frac{\text{energy transferred}}{\text{time taken}}$$

$$P = \frac{W}{t}$$

$$\text{orbital speed} = \frac{2\pi \text{ orbital radius}}{\text{time period}}$$

$$v = \frac{2 \times \pi \times r}{T}$$

$$\frac{\text{pressure}}{\text{temperature}} = \text{constant}$$

$$\frac{p_1}{T_1} = \frac{p_2}{T_2}$$

$$\text{force} = \frac{\text{change in momentum}}{\text{time taken}}$$

Where necessary, assume the acceleration of free fall, $g = 10 \text{ m/s}^2$.

DO NOT WRITE IN THIS AREA

DO NOT WRITE IN THIS AREA

DO NOT WRITE IN THIS AREA



Answer ALL questions.

1 Unstable nuclei can emit particles.

(a) Which of these particles has the largest charge?

(1)

- A** alpha particle
- B** beta particle
- C** neutron
- D** proton

(b) Which of these particles has the largest mass?

(1)

- A** alpha particle
- B** beta particle
- C** neutron
- D** proton

(c) The maximum range of a beta particle in air is about

(1)

- A** 50 mm
- B** 50 cm
- C** 50 m
- D** 50 km

(d) When a nucleus emits a beta particle

(1)

- A** the nucleon number decreases by 1
- B** the nucleon number increases by 1
- C** the proton number decreases by 1
- D** the proton number increases by 1

(Total for Question 1 = 4 marks)

DO NOT WRITE IN THIS AREA

DO NOT WRITE IN THIS AREA

DO NOT WRITE IN THIS AREA



2 A remote control emits infrared waves to operate a television.



Source: www.lemon-digital.co.uk



©science.howstuffworks.com

(a) The television receives infrared waves and radio waves.

It emits light waves and sound waves.

Which type of wave has the highest frequency?

(1)

- A infrared
- B light
- C radio
- D sound

DO NOT WRITE IN THIS AREA

DO NOT WRITE IN THIS AREA

DO NOT WRITE IN THIS AREA



DO NOT WRITE IN THIS AREA

DO NOT WRITE IN THIS AREA

DO NOT WRITE IN THIS AREA

(b) The graph shows how the strength of the infrared signal from the remote control varies with time.

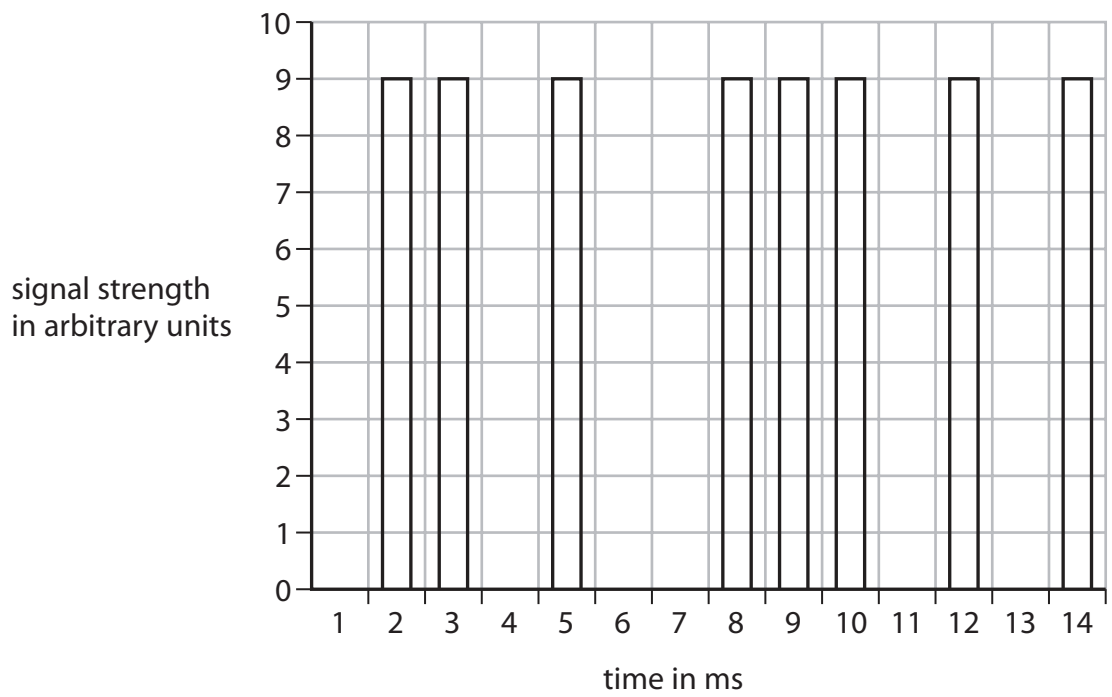

(i) Explain how the graph shows that the infrared signal is digital.

(1)

.....

.....

(ii) Suggest two ways that this signal could be made to carry more information.

(2)

1

.....

2

.....

(Total for Question 2 = 4 marks)



3 A student investigates how air vibrates in a plastic pipe.
She blocks one end of the pipe and blows across the other end.
The pipe emits a sound with a steady pitch.
The student uses a microphone to monitor the sound.

(a) Explain the meaning of the **pitch** of a sound. (2)

.....

.....

.....

.....

(b) The student measures the length of the pipe and the frequency of the microphone signal for two different lengths of pipe.

(i) Name two instruments that she will need for these measurements. (2)

1

2

(ii) Name the dependent and independent variables in her investigation. (2)

dependent variable

independent variable



(c) The student collects this data.

Length of pipe in m	Frequency of signal in Hz
2	42
1½	57

Suggest three ways to improve this investigation.

(3)

1

2

3

(Total for Question 3 = 9 marks)



4 Magnetic field lines show the shape and direction of a magnetic field.

- (a) The diagram shows a cross-section through a wire placed between two magnetic poles.

The wire carries electric current into the page at **X**.

The shape of the magnetic field is shown.

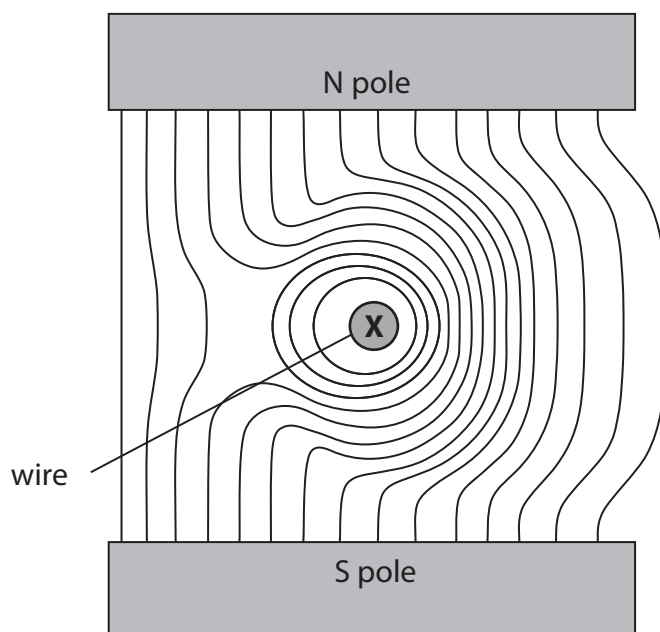

- (i) Add arrows to two of the magnetic field lines to show the direction of the magnetic field. (1)
- (ii) Draw an arrow on the diagram to show the direction of the force on the wire. Label this arrow **F**. (2)



DO NOT WRITE IN THIS AREA

DO NOT WRITE IN THIS AREA

DO NOT WRITE IN THIS AREA

(b) The wire is removed and the magnetic field between the poles changes.

Sketch the new magnetic field.

(2)

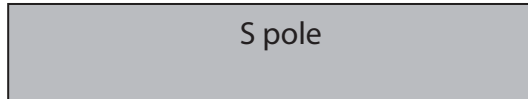
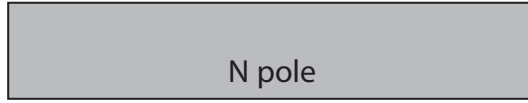

DO NOT WRITE IN THIS AREA

DO NOT WRITE IN THIS AREA

DO NOT WRITE IN THIS AREA

BLANK PAGE



5 A man uses a wheelbarrow to carry some logs along a flat path, as shown.



©http://commons.wikimedia.org/wiki/file:wheelbarrow_%28PSF%29.png

(a) He pushes with a horizontal force of 140 N and the wheelbarrow moves 39 m.

(i) State the relationship between work done, force and distance moved. (1)

(ii) Calculate the work done moving the wheelbarrow. (2)

work done = J

(iii) State how much energy is transferred to the wheelbarrow. (1)

energy transferred = J



(b) The man stops and holds the wheelbarrow horizontally, as shown.

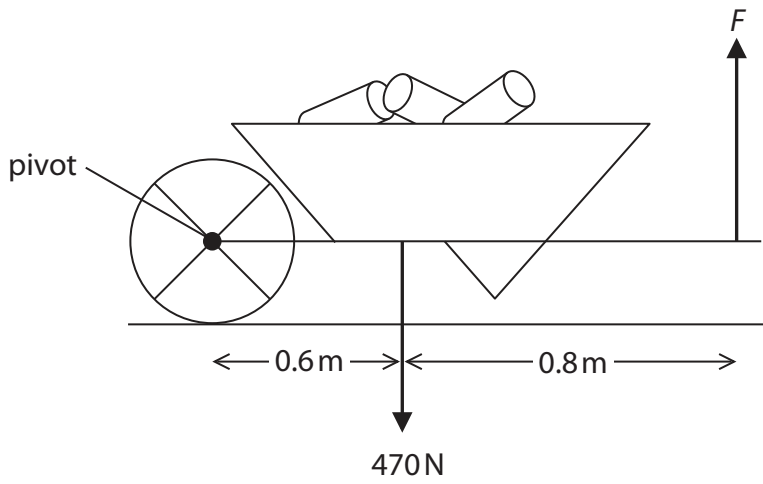

The man exerts a total upward force of F N.
The weight of the loaded wheelbarrow is 470 N.

- (i) Mark X on the diagram to indicate the centre of gravity of the loaded wheelbarrow. (1)
- (ii) State the equation linking moment, force and perpendicular distance from the pivot. (1)
- (iii) Calculate the force F . (4)

force $F = \dots\dots\dots$ N

(Total for Question 5 = 10 marks)

DO NOT WRITE IN THIS AREA

DO NOT WRITE IN THIS AREA

DO NOT WRITE IN THIS AREA



6 The photograph shows a hammer just before it hits a nail.



(a) The mass of the hammer is 0.50 kg.

When it hits the nail, the hammer is travelling downwards with a velocity of 3.1 m/s.

(i) State the relationship between momentum, mass and velocity.

(1)

(ii) Calculate the momentum of the hammer.

(2)

momentum = kg m/s

(iii) The hammer stops quickly when it hits the nail.

The momentum of the hammer reduces to zero in 0.070 s.

Calculate the amount of force that causes this to happen.

(2)

force = N



(b) As it enters the wood, the nail exerts a force on the wood.
At the same time, the wood exerts a force on the nail.
Explain how these two forces are related.

(2)

.....

.....

.....

.....

.....

.....

(c) Both ends of the nail exert pressure when the nail goes into the wood.

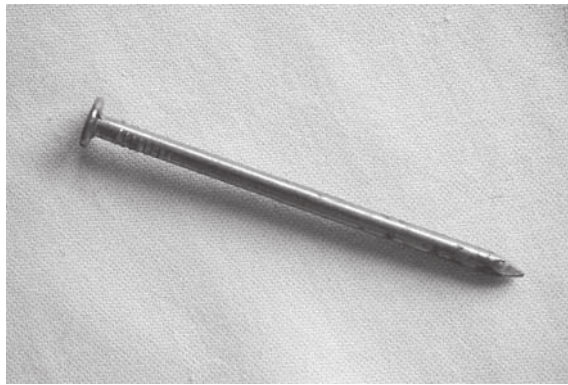

Explain why the nail exerts more pressure on the wood than it does on the hammer.

(2)

.....

.....

.....

.....

.....

.....

(Total for Question 6 = 9 marks)



7 A man pushes a metal trolley along a corridor towards a lift.

The trolley has nylon wheels and the floor of the corridor is covered with plastic.

The man wears shoes with rubber soles.



As he moves the trolley, the man gains an electric charge.

(a) Explain how the man gains an electric charge.

(2)



(b) The man presses a metal button to operate the lift.

There is a spark and the man receives an electric shock.

The spark lasts for 75 ms and 0.0017 C of charge passes.

(i) State the equation linking charge, current and time. (1)

(ii) Calculate the average current in the spark.
Give the unit. (3)

current = unit

(c) Metal appliances, such as the lift button, are earthed for safety.

Explain why the man receives a shock even though the button is properly earthed. (3)

.....

.....

.....

.....

.....

.....

.....

.....

.....

.....

.....

(Total for Question 7 = 9 marks)



8 A cooling tower is designed to transfer thermal energy away from a power station.



© Copyright Alan Murray-Rust

(a) Thermal energy from the power station warms the air inside the cooling tower.

Air enters through holes at the bottom of the cooling tower and leaves through the top.

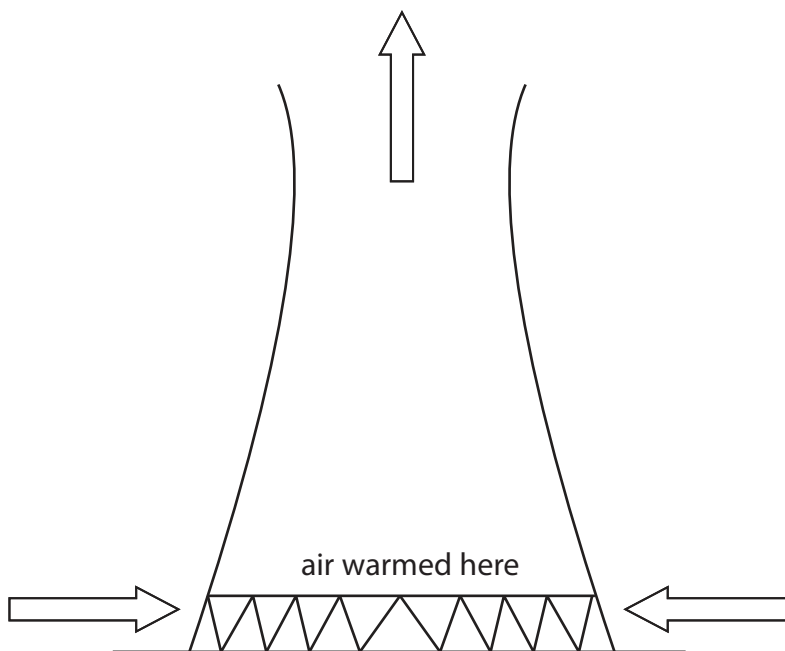

Explain why the air moves as shown by the arrows.

(4)

.....

.....

.....

.....

.....

.....

.....

.....



- (b) Hot water from the power station is sprayed into the cooling tower, as shown.
As it falls through the air, some of the hot water evaporates.
The rest of the water is collected and returned as cold water to the power station.

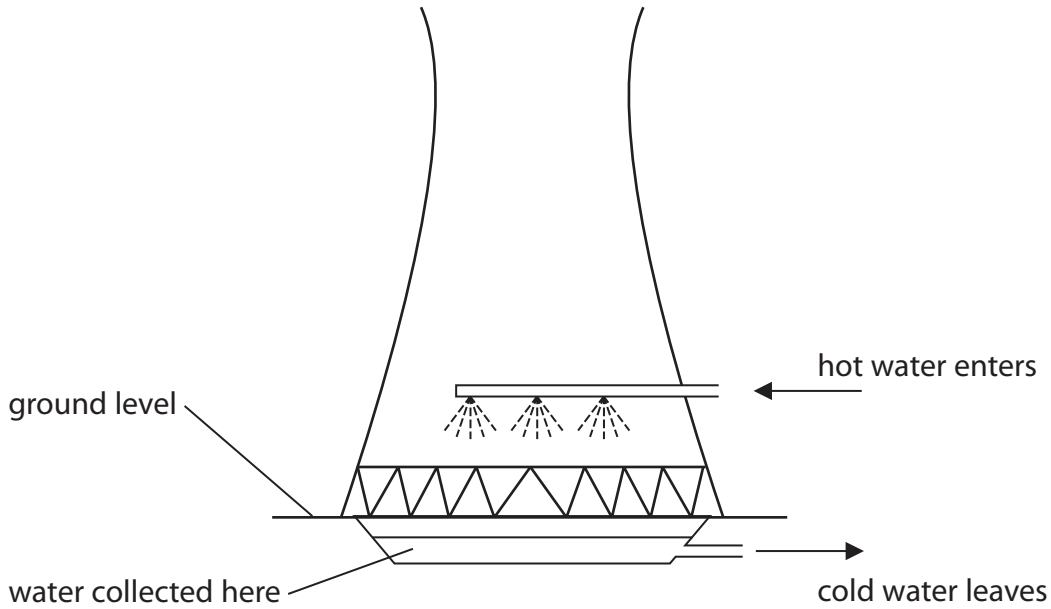

Explain how evaporation cools the water.

(3)

.....

.....

.....

.....

.....

.....

.....

.....

.....

.....

(Total for Question 8 = 7 marks)

TOTAL FOR PAPER = 60 MARKS



DO NOT WRITE IN THIS AREA

DO NOT WRITE IN THIS AREA

DO NOT WRITE IN THIS AREA

BLANK PAGE

Every effort has been made to contact copyright holders to obtain their permission for the use of copyright material. Pearson Education Ltd. will, if notified, be happy to rectify any errors or omissions and include any such rectifications in future editions.

